

# Landscape Specification Details

## Tree Planting Detail, 14-16cm girth, rb Scale 1:50

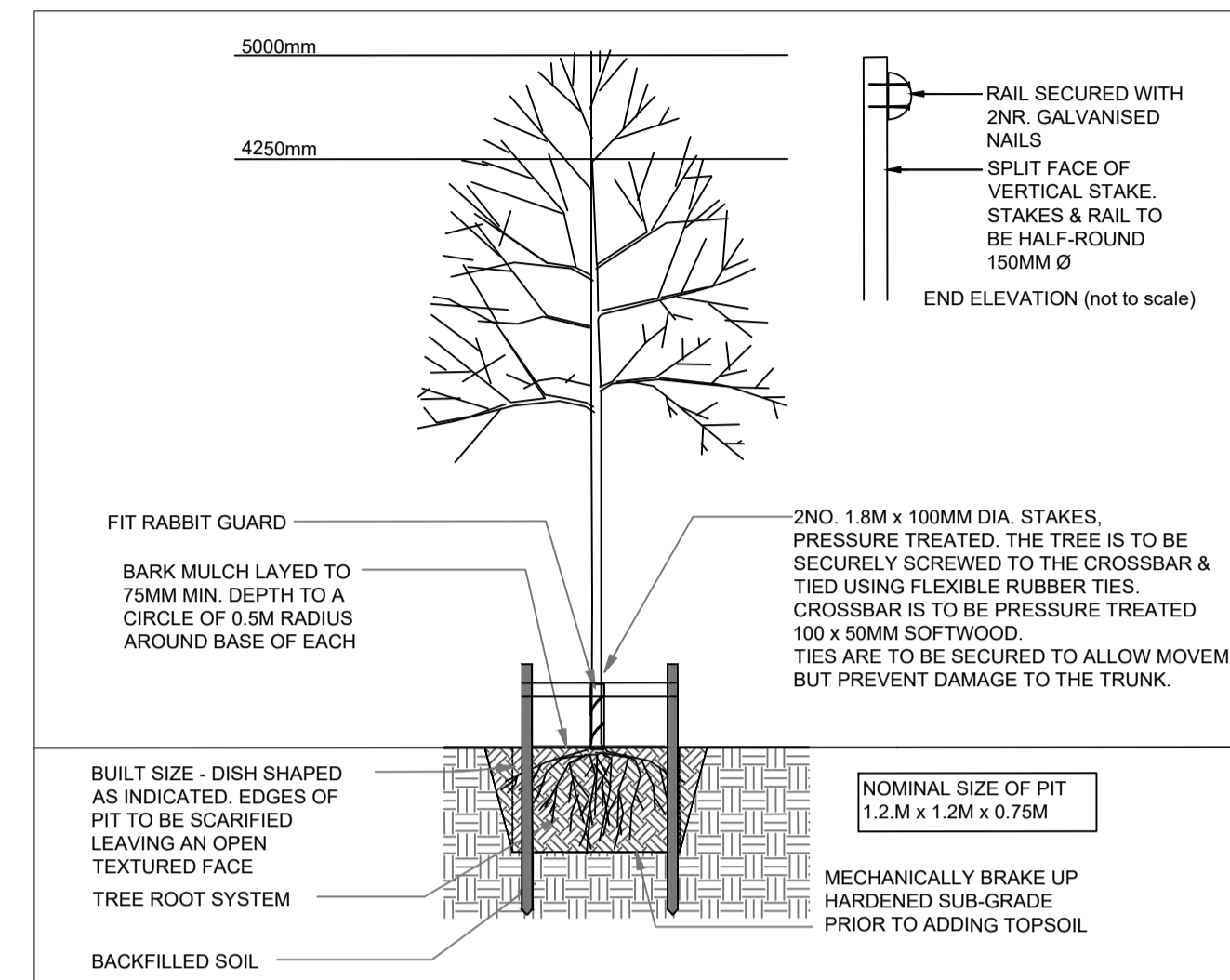

## Typical Double Tree Staking Detail Scale (1:25)

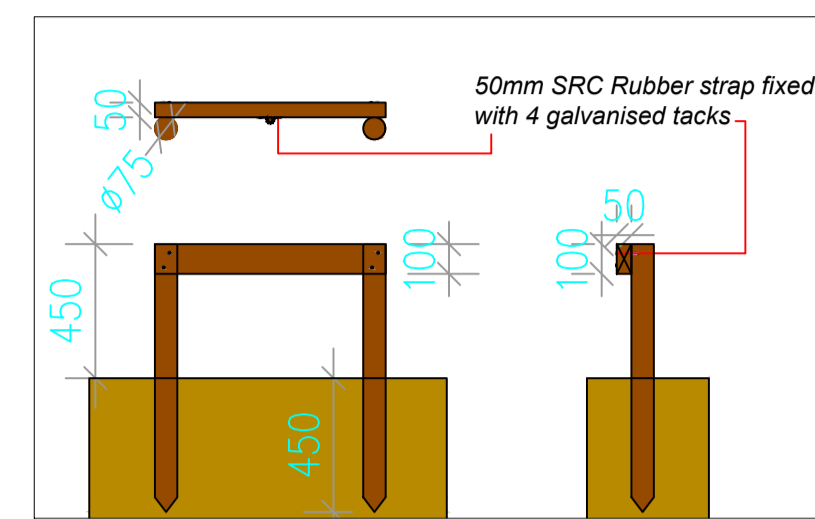

## Minimum Soil Depths (Scale 1:20)

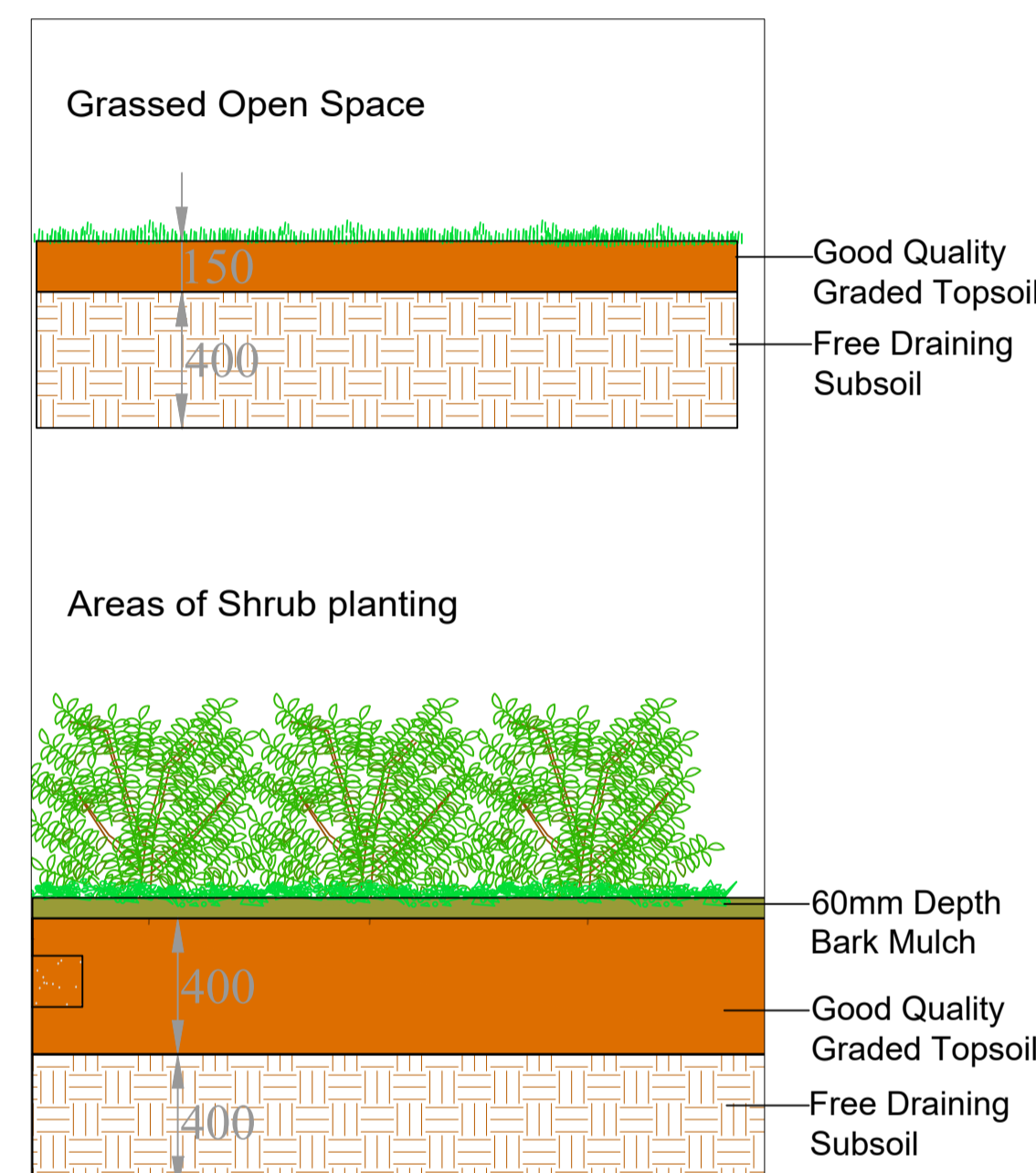

## Single Tree Staking Detail Scale (1:25)

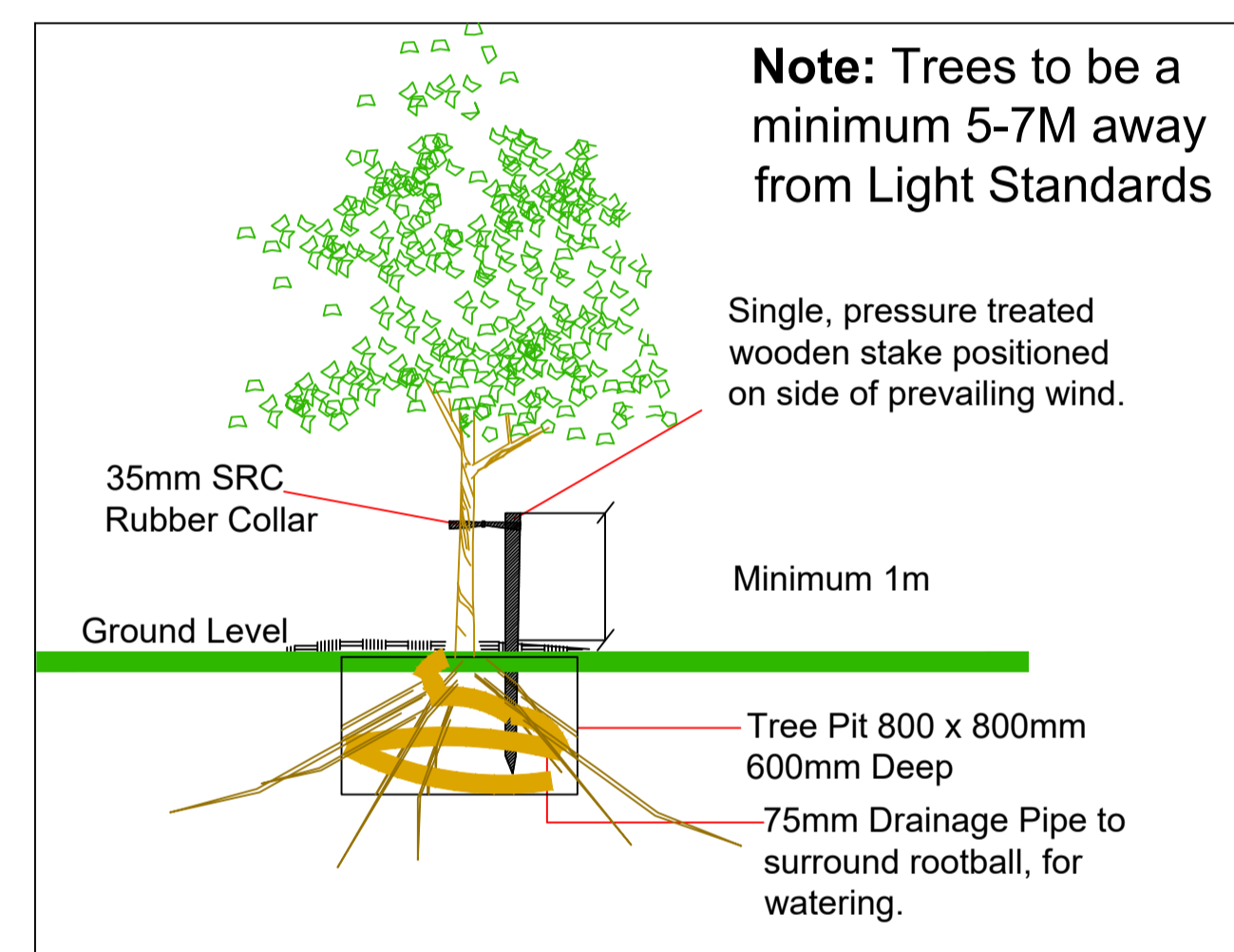

## Shrub Planting Detail

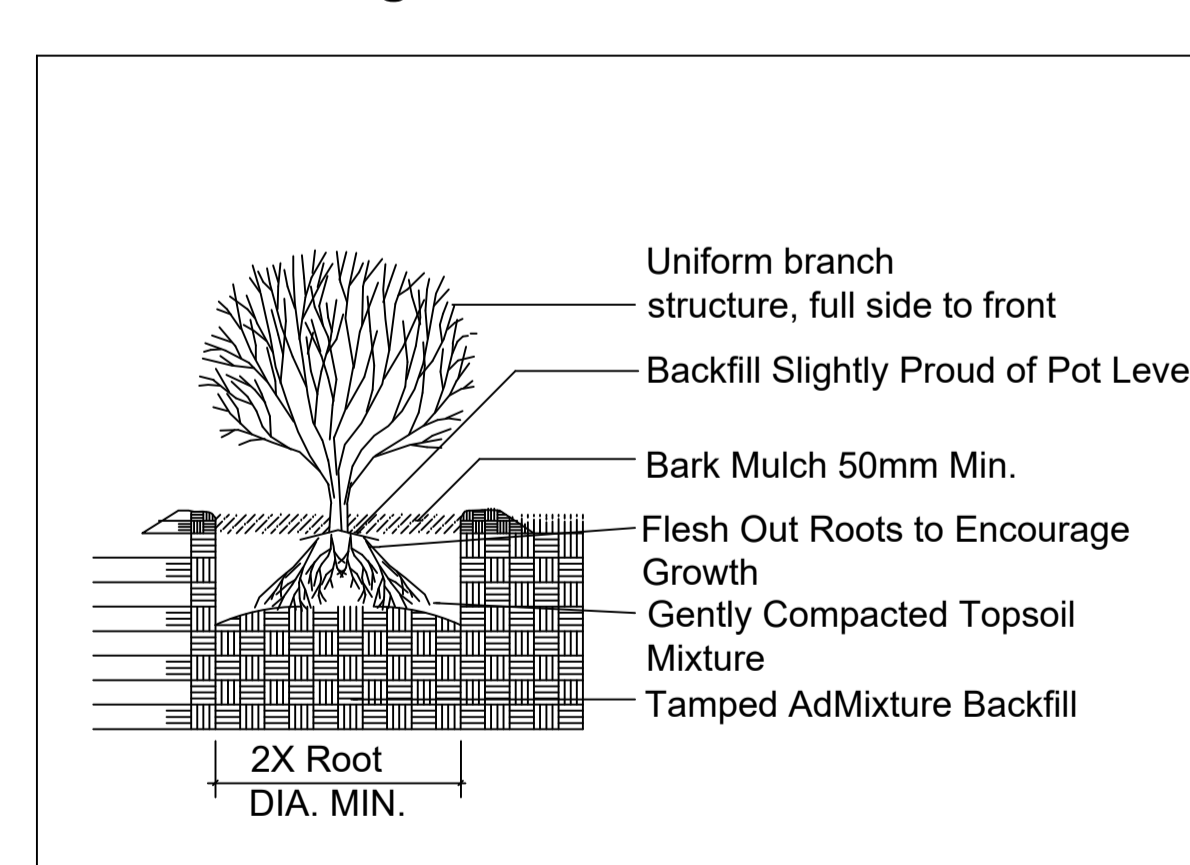

## Typical Detail of Gravel Drainage Against House Front - (Scale 1:5)

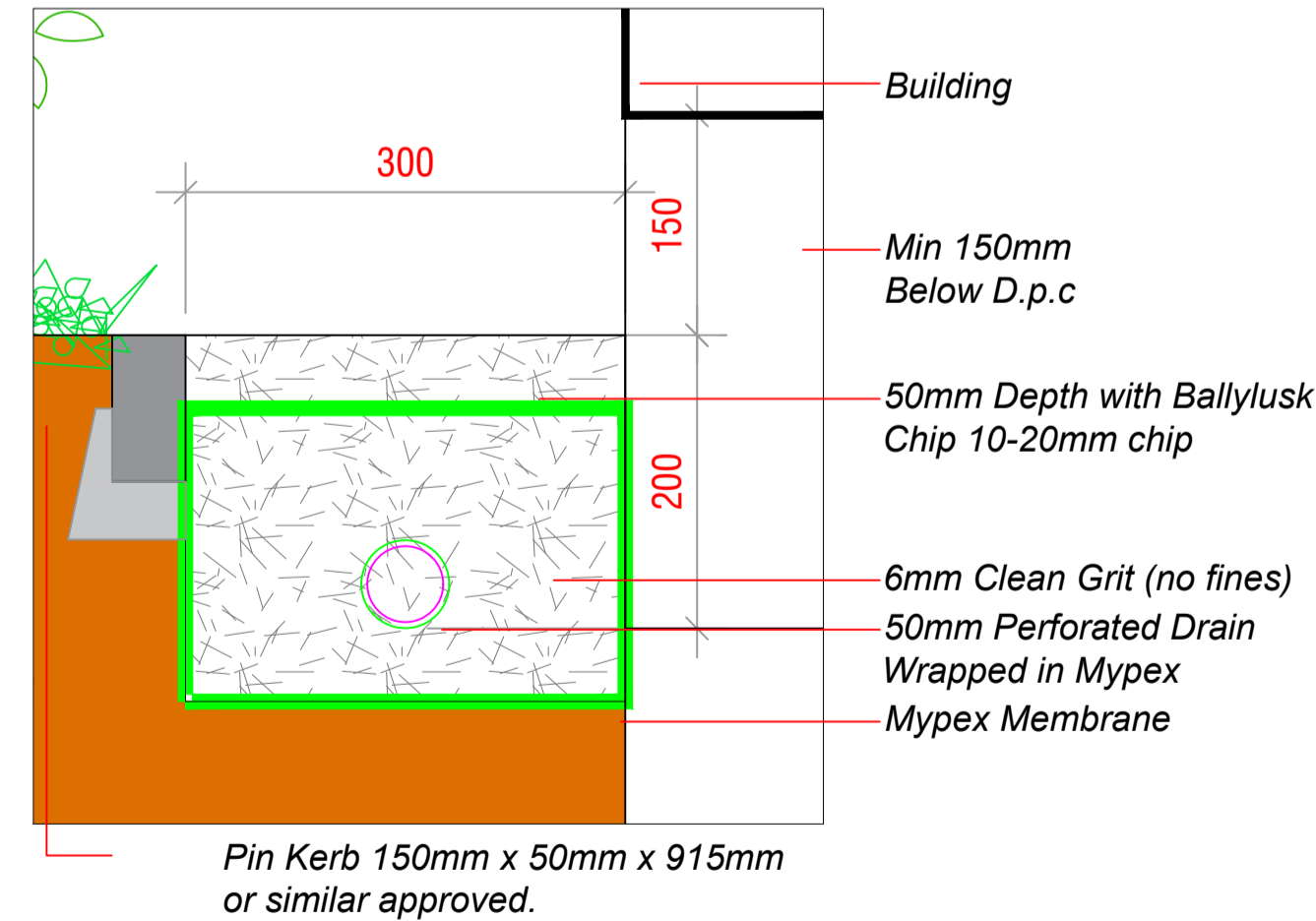

## Urban Tree Planting Detail Scale 1:25 (Subject to Services on Site)

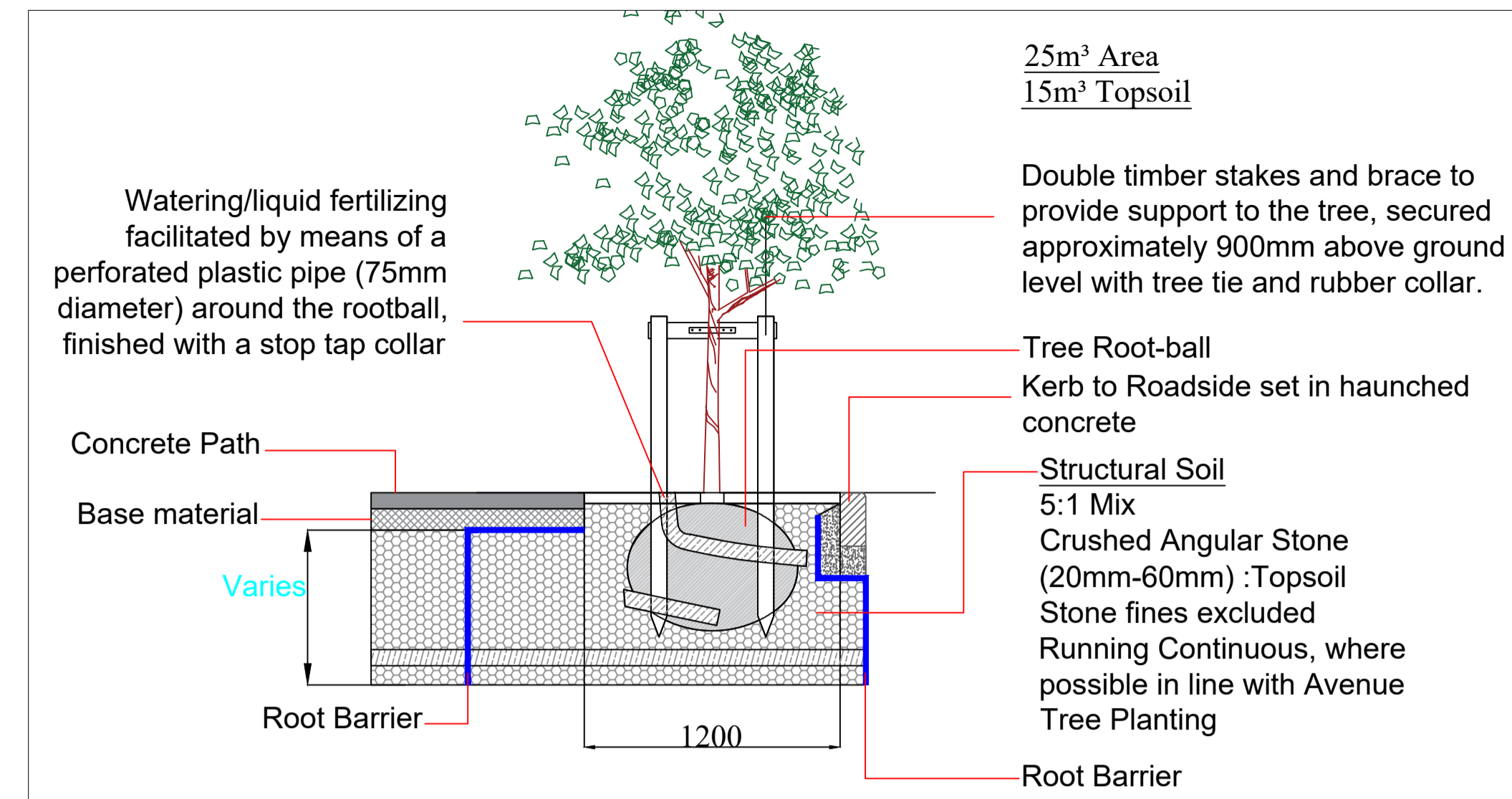

## Typical Streetscape Section Scale 1:25

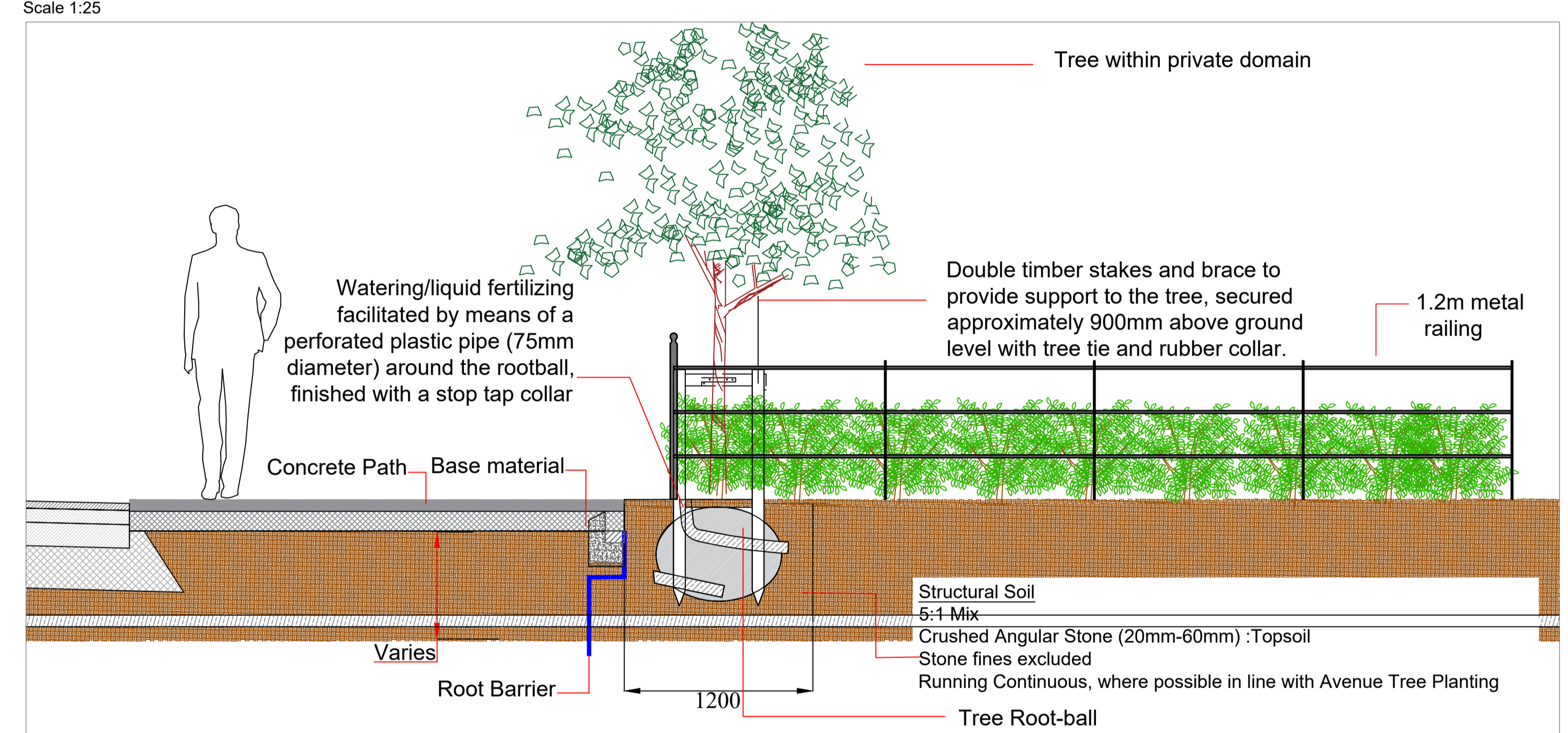

### PROPOSED PLANTING SCHEME

#### Proposed Tree Planting

No.	Name
T1	Acer campestre 'Elsrijk'
T2	Amelanchier grandiflora (3 stem min)
T3	Betula pendula multistem (4 stem min)
T4	Sorbus cashmiriana
T5	Arbutus unedo
T6	Acer griseum
T7	Aesculus hippocastanum
T8	Corylus colurna
T9	Quercus robur fastigiata
T10	Pinus sylvestris
T11	Tilia cordata 'Greenspire'
T12	Pyrus chanticleer

#### Proposed Shrub Defensive Planting

No.	Name
S1	Lavandula angustifolia
S2	Prunus otto luyken
S3	Prunus laurocerasus

#### Proposed Groundcover Planting

No.	Name
G1	Persicaria affinis
G2	Berginia cordiflora
G3	Libertia grandiflora
G4	Helleborus niger

#### Proposed Hedgerow Planting h1

Name
Elaeagnus x ebbingei

#### Proposed Bulb Planting (House fronts)

No.	Name
B1	Schizostylis coccinea
B2	Kniphofia 'Royal Standard'
B3	Hemerocallis tejas
B4	Crococsmia citronella

#### Proposed Bulb Planting (Open Space)

No.	Name
B1	Narcissus spp.
B2	Allium spp.
B3	Camassia spp.
B4	Tulipa spp.

Description	By	Date	Proposed Residential Development at - Steeles Road, Duleek, Co. Meath	Scale: Varies	Dwg: 04
Rev A	Layout and engineer details	PR	18.09.19	Client: Davy Target Investments ICAV	Date: 13.09.19
Rev B	Revised layout	PR	19.09.19	Drawing Title: Landscape Specification Details	Drawing By: PR
Rev C	Revised layout	PR	20.09.19	Job No.: 2019 - 1506	Checked By: RMD
Rev D	New Site Layout	PR	24.01.20	<b>Ronan MacDiarmada + Associates Ltd.</b> Landscape Architects and Consultants. Tootenhill, Rathcoole, Co. Dublin tel: +353 1 412 4476 mob: 086 26 25 438 e-mail: ronan@rmda.ie	
Rev E	New Site Layout	PR	21.02.20		
Rev F	Revised Layout and Details	PR	24.03.20		
Rev G	Revised Road Crossings	PR	02.04.20		
Rev G1	Revised Site Layout	PR	13.05.20		